

# TB42/TB47J

## TELESCOPIC BOOM LIFT



- Mid-size diesel telescopic boom lifts
- Available with and without a jib boom
- 4 wheel drive for excellent rough terrain performance
- Simple to operate and maintain
- Ideal for construction and industrial applications

 **snorkel**  
[www.snorkellifts.com](http://www.snorkellifts.com)

# TELESCOPIC BOOM LIFT

# TB42/TB47J

DIMENSIONS	TB42	TB47J
Max. working height	48 ft	53 ft
Max. platform height (A)	42 ft	47 ft
Max. horizontal reach	33 ft	39 ft
Platform size	8 ft x 3 ft	8 ft x 3 ft
Overall width (B)	7 ft 11.5 in	7 ft 11.5 in
Stowed length (C)	24 ft	26 ft 9 in
Stowed height (D)	7 ft 9.5 in	7 ft 9.5 in
Wheelbase	8 ft	8 ft
Ground clearance	10 in	10 in

PERFORMANCE		
Platform capacity	500 lbs	500 lbs
Max. drive height	42 ft	47 ft
Max. wind speed	28 mph	28 mph
Max. drive speed (stowed)	3.0 mph	3.0 mph
Max. drive speed (elevated)	0.75 mph	0.75 mph
Jib length	n/a	5 ft
Jib arc	n/a	140°
Platform rotation	157°	150°
Superstructure rotation	360° continuous	360° continuous
Tailswing	49 in	49 in
Gradeability	25%	25%
Inside turning radius	13 ft 6 in	13 ft 6 in
Outside turning radius	19 ft 9 in	19 ft 9 in
Tires	12 in x 16.5 in pneumatic lug	
Controls	proportional drive, lift and swing	
Drive system	4 wheel drive	4 wheel drive

POWER	
Power source	Kubota V1505 25hp Turbo Diesel Tier 4 Final

WEIGHT		
Weight	11,600 lbs	13,500 lbs

## WORKING ENVELOPE

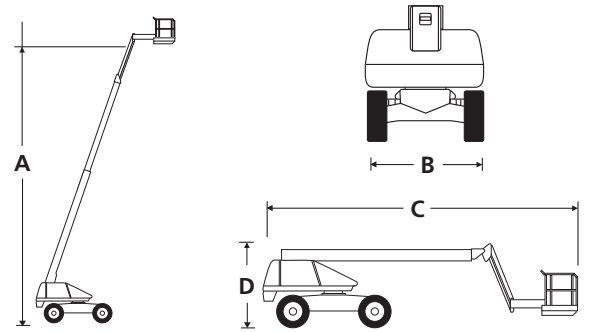
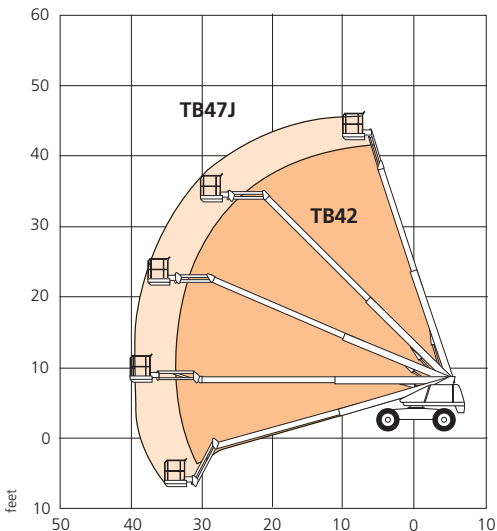

## STANDARD FEATURES

- Snorkel Guard™ secondary guarding system
- 5 ft, 140° jib (TB47J only)
- Hydraulic platform rotation
- Four wheel drive
- 5° tilt alarm
- Proportional drive, lift & swing
- Power line to platform
- Rheostat control for jib, extend & platform level
- Drive motion alarm
- Flashing amber light
- Dual lanyard attachment points
- Horn
- Hour meter
- 2 year parts & labor, 5 year structural warranty
- ANSI compliant

## OPTIONS

- Special paint colors
- Airline to platform
- AC generator 110V/240V
- Foam filled tires
- Non-marking tires
- Pneumatic high floatation turf tire
- Cold weather package
- Extreme cold weather package
- Extreme environment package
- Light package
- Tow package
- Glazier package
- 12k generator package
- 12k generator/welder package
- CSA compliant

**snorkel** [www.snorkellifts.com](http://www.snorkellifts.com)

P.O. Box 1160  
 St. Joseph, MO 64502-1160, USA  
 Tel: 1 (785) 989-3000  
 Toll-free: 1 (800) 255-0317  
 Fax: 1 (785) 989-3070  
 Email: sales.usa@snorkellifts.com